



The area of the Cornus basilicas

Patrimonio culturale
SARDEGNA Virtual Archaeology



■ Barrow burials

There are several tomb types in the cemetery areas of Columbaris (figs. 1-2). Some going continuously from the IV to the VII century A.D., period during which the cemetery was used. Of the 157 tombs analysed there are 5 barrow burials.

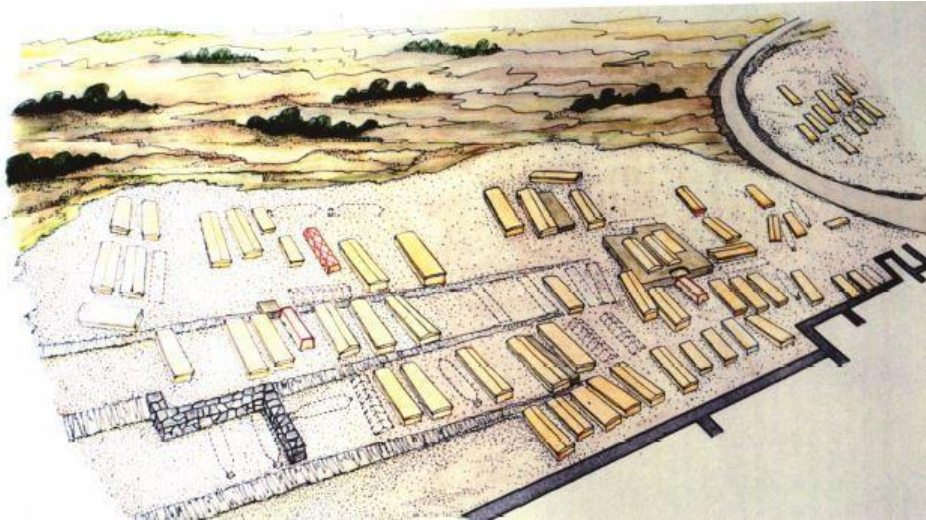

Fig. 1 - Reconstruction of the funeral area (from *Cornus* I.1, p. 203, Tab. IV).

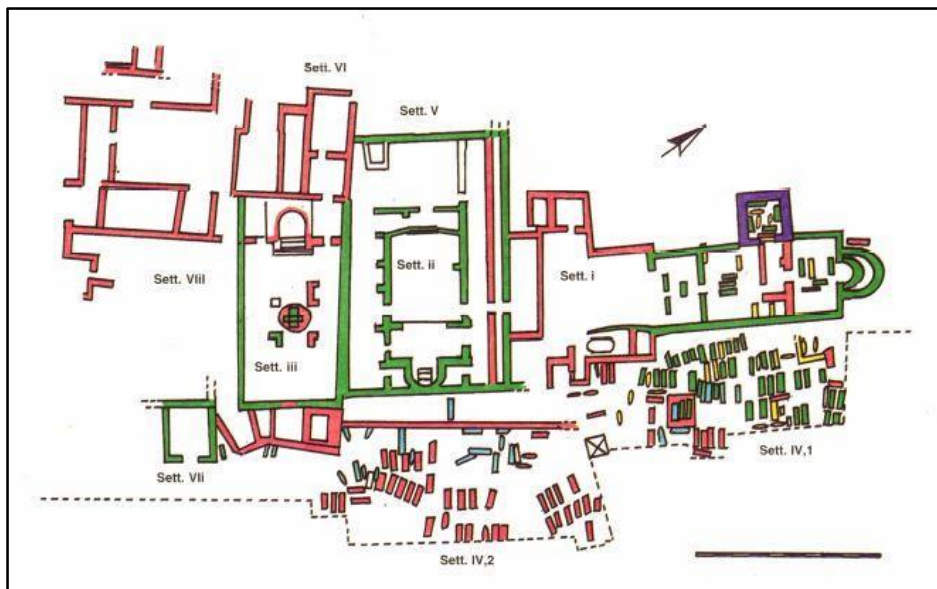

Fig. 2 - Map of the Columbaris-Cornus complex with indication of stages and sectors (drawing by L. SALADINO, M. C. SOMMA, from *Cornus* I.1, p. 200, tab. II).

The **barrow burials** (fig. 3) are characterised by a prismatic or oval brick cover made with stone pieces (limestone and phonolite) and brick fragments bound with mortar. On the outside, the latter was covered in an *Opus signinum* layer or finer plaster which has preserved traces of red decoration, painted with linear motifs (t. 71 fig. 4) or plant motifs (t. 68). some plastered pavements were found around the tombs (fig.5), on which deposits of ceramic and glass ornaments and food offerings were found, connected with the carrying out of funeral banquets. The barrow tombs were widely documented in Sardinia and have been compared with African and Iberian contexts.

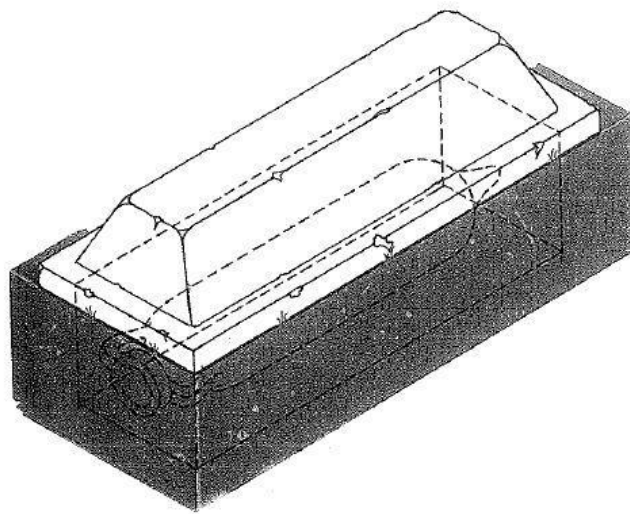

Fig. 3 - Drawing of two barrow tombs (from *Cornus* I.1, p. 216, fig. 85).

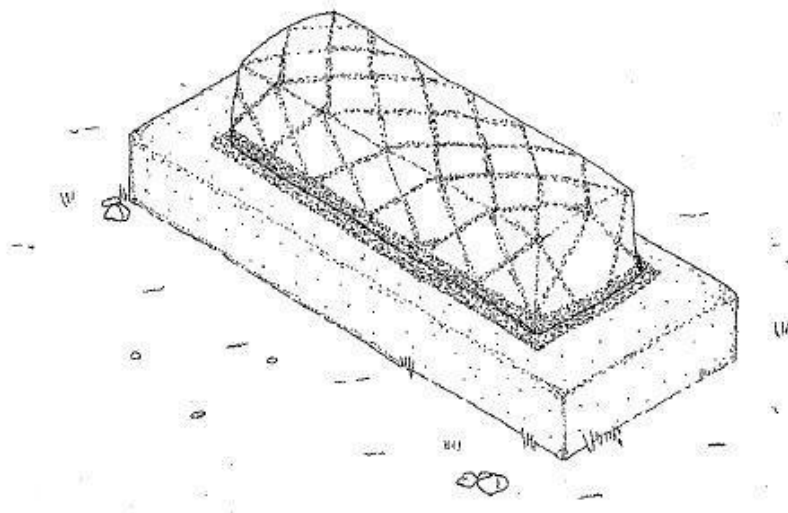

Fig. 4 - Perspective reconstruction of barrow tomb no. 71 (from *Cornus* I.1, p. 216, fig. 86; p. 218, fig. 90).

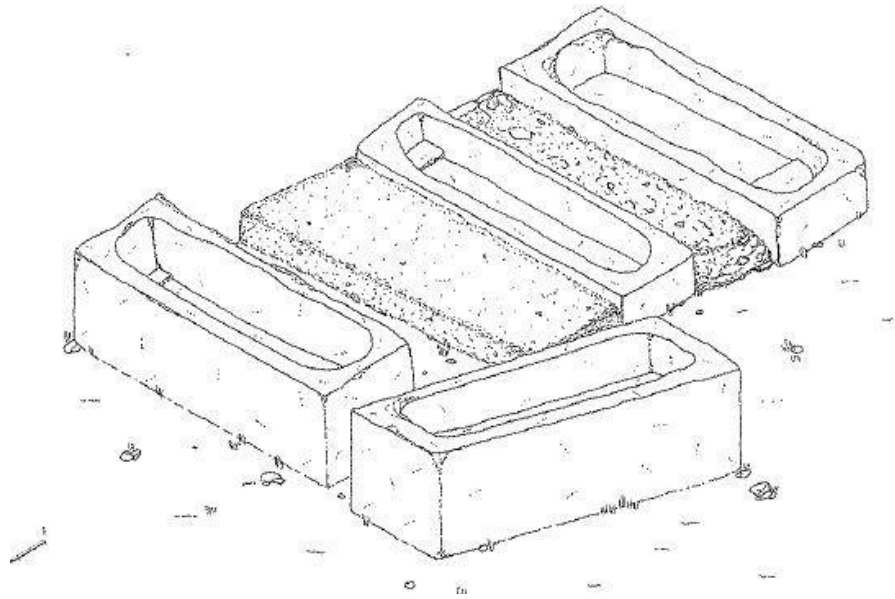

Fig. 5 - Axonometry of tombs 25, 27 e 117 with pavements (from *Cornus* 1.1, p. 221, fig. 86; p. 218, fig. 97).

In the Christian necropolis, along with capuchin tombs you also mainly have tombs dug into the rock directly, *enchytrismos*, at times surmounted by brick mounds flanked by small tables for the *refrigerium*. Sarcophagi also appeared during the area's maximum expansion period. Between the end of the VI and the VII century A.D., especially in sector IV,2, you have burials in clay caskets or using stone pieces; some trapezoidal in shape, thus called anthropomorphic.

■ Credits

Deepening card edited by Dr. Claudia Cocco and Dr. Francesca Collu

■ Bibliographic abbreviations

- AMANTE SIMONI 1987b C. AMANTE SIMONI, *I corredi*, in AMANTE SIMONI *et al.* 1987, pp. 83-86.
- AMANTE SIMONI *et al.* 1987 C. AMANTE SIMONI, A. M. GIUNTELLA, L. PANI ERMINI, D. STIAFFINI, *Ricerche di archeologia post-classica nella Sardegna centro-medievale*, in QuadCa 4, II, 1987, pp. 79-103.
- BACCHIELLI 1986 L. BACCHIELLI, *Monumenti funerari in forma di cupola: origine e diffusione in Italia Meridionale*, in "L'Africa romana" III, pp. 303-319.
- Cornus I.1 A. M. GIUNTELLA, *Cornus I.1. L'area cimiteriale orientale = Mediterraneo tardoantico e medievale. Scavi e ricerche*, 13. 1, Oristano 1999.
- CUGLIERI IV AA. VV., *Le sepolture in Sardegna dal IV al VII secolo. IV Convegno sull'archeologia tardoromana e medievale* (Cuglieri 27-28 giugno 1987) = *Mediterraneo tardoantico e medievale. Scavi e ricerche*, 8, Oristano 1990.
- GIUNTELLA *et al.* 1985 A. M. GIUNTELLA, G. BORGHETTI, D. STIAFFINI, *Mensae e riti funerari in Sardegna: la testimonianza di Cornus = Mediterraneo Tardoantico e medievale. Scavi e ricerche*, 1, Taranto 1985.
- "L'Africa romana" III A. MASTINO (a cura di), *L'Africa romana. Atti del III Convegno di studio (Sassari, 13-15 dicembre 1985)*, Sassari 1986.

LISSIA, ROVINA 1990 D. LISSIA, D. ROVINA, *Sepolture tardo romane e altomedievali nella Sardegna nord-occidentale e centrale*, in CUGLIERI IV, pp. 75-100.

MUREDDU, STEFANI 1986 D. MUREDDU, G. STEFANI *Il mosaico funerario africano*, in "L'Africa romana" III, pp. 339-356.

■ Periodicals and magazines

QuadCa

Quaderni della Soprintendenza Archeologica per le Province di Cagliari e Oristano, Cagliari, I, 1986 e ss.





UNIONE EUROPEA



REPUBBLICA ITALIANA



REGIONE AUTÒNOMA DE SARDIGNA
REGIONE AUTONOMA DELLA SARDEGNA

La Sardegna cresce con l'Europa



UNIONE EUROPEA

Progetto cofinanziato dall'Unione Europea
Programma Operativo FESR 2007-2013

FESR - Fondo Europeo di Sviluppo Regionale - Asse I, Linea di Attività 1.2.3.a