



UNIONE EUROPEA



REPUBBLICA ITALIANA



REGIONE AUTÒNOMA DE SARDIGNA
REGIONE AUTONOMA DELLA SARDEGNA

Archaeological area of Mount Sirai

Patrimonio culturale
SARDEGNA Virtual Archaeology



■ Items from the chamber tombs

The burial items in the chamber tombs on Monte Sirai (figs. 1-2) show - in the new Carthaginian phase that follows the Phoenician presences - both the continuation of the materials (ceramics, amulets, jewellery) and the presence of new Greek influences (particularly from Athens) and renewed Mediterranean relations from the end of the 6th to the 3rd century BC.

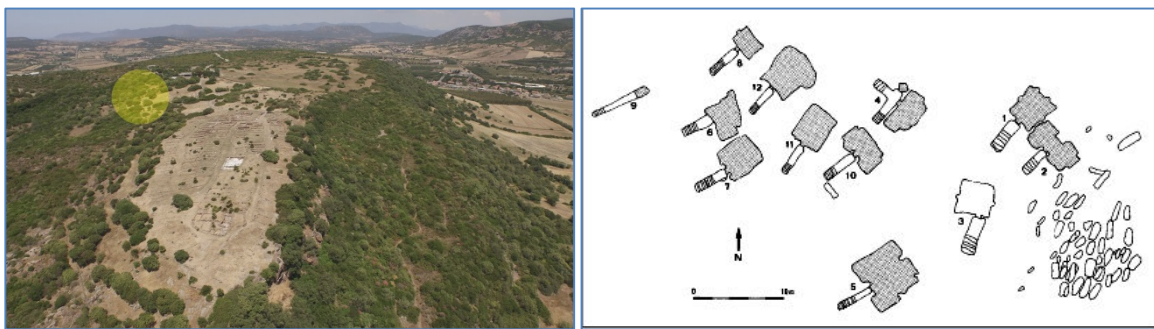

Figs. 1, 2 - The area of the hypogeum necropolis (highlighted): photo Unicity 2015; Map (BARTOLONI 2004, fig. 24).

For the 5th century BC, we therefore have *oinochoai* (jugs) with a mushroom and lobed rim. The use of red slip gradually disappeared. The jugs underwent a formal evolution with new colour schemes. Other known types of pottery appeared, such as amphorae, plates and cups. There is considerable documentation of scarabs, such as in tomb II.

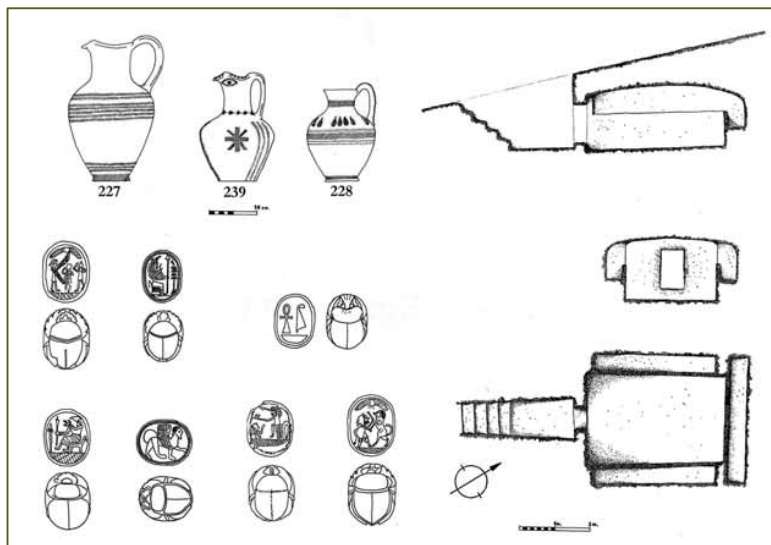

Figs. 3, 5 - Items from tomb 11 (BARTOLONI 2004, figs. 47-48) and tomb II (GUIRGUIS 2013, fig. 42).

■ Credits

Deepening card edited by Dr. Giuseppina Manca di Mores and Prof. Marcello Madau

■ Bibliography

BARTOLONI 2004 = P. BARTOLONI, *Monte Sirai*, Sassari.

GUIRGUIS 2013 = M. GUIRGUIS, *Monte Sirai 1963-2013 mezzo secolo di indagini archeologiche*, Sassari.





UNIONE EUROPEA



REPUBBLICA ITALIANA



REGIONE AUTÒNOMA DE SARDIGNA
REGIONE AUTONOMA DELLA SARDEGNA

La Sardegna cresce con l'Europa



UNIONE EUROPEA

Progetto cofinanziato dall'Unione Europea
Programma Operativo FESR 2007-2013

FESR - Fondo Europeo di Sviluppo Regionale - Asse I, Linea di Attività 1.2.3.a